

## **Getting into the Flow: Understanding Connectors in Revit MEP Content**

Martin Schmid, P.E. – Autodesk

**ME204-3** This class will dive into the details of how connectors propagate data in Revit MEP. This class goes beyond basic geometric and data modeling of content, and demonstrates how the definition of connectors affects the data available on pipe and duct networks, as well as electrical circuits.

### **About the Speaker:**

Martin has been working with customers to identify best practices and workflows using Autodesk MEP solutions for over three years. Martin is a recovering electrical engineer, and in his former life, worked for architects, contractors, and MEP firms, both as a design engineer as well as a IT/CAD administrator. Martin has Master's degrees in Engineering and Business.



## Contents

Introduction .....	5
Hosted Components and Linked Models .....	5
Room Air Tabulations.....	5
Air Terminal Family Settings .....	5
Task .....	6
Room Flows.....	6
Task .....	7
Duct System Flows .....	7
Supply Air Distribution .....	7
Duct Connector Settings .....	8
Task .....	8
Task .....	8
Task .....	8
Task .....	8
Task .....	9
Task .....	9
Creating Duct Systems .....	9
Pipe System Flows.....	9
Chilled Water Loop .....	9
Task .....	10
Condenser Water Loop .....	11
Pumps Piped in Parallel (System Flow Configuration) .....	11
Task .....	12
Task .....	12
Task .....	12
Fire Protection Systems .....	12
Creating Pipe Systems.....	12
Power System Tabulations.....	13
Electrical Distribution.....	13

Task .....	14
Task .....	15
Electrical Loads.....	15
Voltage .....	17
Load Classification.....	17
Load.....	18
Number of Poles .....	18
Task .....	19
Lighting Content.....	19
Task .....	20
References .....	20
Autodesk University .....	20
Product Tutorials.....	20
Internet Postings.....	20
Reference Matrix .....	21

## Introduction

The intent of this class is to help you understand how the flow parameters on connectors in Revit MEP content affect your modeling efforts.

There isn't any single 'correct' way to build MEP content, just as there is no single correct way to design a building. There are, however, ways that incorrectly defining content will result in the perception that the application isn't working as intended (i.e., flows not propagating through a VAV box, for example). Having an understanding of how components work in a building and within Revit MEP will help you understand how to achieve the desired result when creating content.

Following these three simple principles will help ensure that the content you create functions as expected:

1. Don't try to create content 100% from memory. In general, it is best when creating content to use an existing family as a basis of comparison. Looking at someone else's work isn't cheating.
2. Compare all Family Category and Parameters settings (Settings > Family Category and Parameters...).
3. Compare as all connector properties (the focus of this document).

Although, in most cases, there will be a family created that has the settings to achieve the result you desire, don't assume that this is always the case. There are always unique situations that will require a little creativity and a deeper understanding of how Revit MEP functions to achieve a specific result.

## Hosted Components and Linked Models

It is not possible to host wall, ceiling, floor, roof, or line based families through a link. To accommodate similar functionality, the concept of face based families was introduced with the initial release of Revit MEP (Revit Systems). These families can host on any face through a link or in the same file. If the linked host moves (i.e., ceiling shifts up, wall moves), the component will move accordingly. Note, however, if the ceiling grid moves in plane, the component will not move accordingly.

## Room Air Tabulations

One of the fundamental tasks in mechanical design is distributing air. Supply air is used to deliver tempered air to heat or cool a space. Return air facilitates circulation of air through a space and back to the air distribution equipment. Exhaust air removes fouled air from a space.

## Air Terminal Family Settings

Essential to this air distribution concept in Revit MEP are Air Terminals. There are three Categories of Air Terminals: Supply, Return, and Exhaust. The primary settings for an Air Terminal Family are shown below.

	Supply	Return	Exhaust
Family Category	Air Terminals		
Behavior Type	Normal		

Table: Air Terminal Family and Category Parameters settings

	Supply	Return	Exhaust
Flow Configuration	Preset		
Flow Direction (Relative to Connector)	In <sup>1</sup>	Out <sup>2</sup>	
Pressure Drop	Per manufacturer's catalog <sup>3</sup>		

Table: Air Terminal Duct Connector settings

1. Air goes IN the diffuser from the duct.
2. Air leaves the diffuser OUT to the duct.
3. Shown below is a sample data table from a manufacturer's catalog. The Pressure Drop is listed as Total Pressure.

### Performance Data

#### TMS • Square Ceiling • Round Neck • High Performance

		Neck Velocity	400	500	600	700	800	1000	1200	1400	1600
		Velocity Pressure	0.010	0.016	0.022	0.031	0.040	0.062	0.090	0.122	0.160
12" x 12" Module Size	4"	Airflow, cfm	35	44	52	61	70	87	105	122	140
		Total Pressure	0.012	0.018	0.026	0.035	0.046	0.072	0.104	0.141	0.184
		Di. NC (Noise Criteria)	-	-	-	-	12	20	26	31	36
		Throw feet	1-1-3	1-2-4	1-2-4	2-3-5	2-3-6	2-4-7	3-4-7	3-5-8	4-6-8
	5"	Airflow, cfm	55	68	82	95	109	136	164	191	218
		Total Pressure	0.015	0.023	0.033	0.044	0.058	0.091	0.131	0.178	0.232
		Di. NC (Noise Criteria)	-	-	-	-	15	23	29	34	39
		Throw feet	1-2-4	2-2-5	2-3-6	2-3-7	2-4-7	3-5-8	4-6-9	4-7-10	5-7-10
	6"	Airflow, cfm	79	98	118	137	157	196	236	275	314
		Total Pressure	0.018	0.028	0.041	0.056	0.073	0.114	0.164	0.223	0.291
		Di. NC (Noise Criteria)	-	-	-	13	18	25	32	37	42
		Throw feet	2-2-5	2-3-6	2-3-7	3-4-8	3-5-9	4-6-10	5-7-11	5-8-12	6-9-13
	7"	Airflow, cfm	107	134	160	187	214	267	321	374	428
		Total Pressure	0.020	0.031	0.045	0.062	0.081	0.126	0.181	0.247	0.322
		Di. NC (Noise Criteria)	-	-	-	15	20	28	34	39	44
		Throw feet	2-3-5	2-3-7	3-4-8	3-5-9	4-5-10	4-7-12	5-8-13	6-9-14	7-10-15
	8"	Airflow, cfm	140	175	209	244	279	349	419	489	559
		Total Pressure	0.022	0.035	0.050	0.069	0.090	0.140	0.202	0.275	0.359
		Di. NC (Noise Criteria)	-	-	12	17	22	29	36	41	46
		Throw feet	2-3-6	3-4-8	3-5-9	4-5-11	4-6-12	5-8-13	6-9-14	7-11-16	8-12-17

**Task:** Create supply, return, and exhaust air terminals from scratch, and place some of each in a building with Spaces defined.

### Room Flows

It is easy to verify the effect of an air terminal on a Space. A schedule as shown below is a simple engineering tool that may be used to validate the design compared to an engineering analysis.

Room Schedule					
Name	Number	Actual Exhaust Airflow	Actual Supply Airflow	Actual Return Airflow	Room Pressurization
Room	1	235.0 L/s	0.0 L/s	470.0 L/s	-705.0 L/s
Room	2	470.0 L/s	940.0 L/s	1175.0 L/s	-705.0 L/s
Room	3	0.0 L/s	470.0 L/s	235.0 L/s	235.0 L/s
Room	4	0.0 L/s	0.0 L/s	235.0 L/s	-235.0 L/s
Room	5	470.0 L/s	235.0 L/s	470.0 L/s	-705.0 L/s
Room	6	235.0 L/s	470.0 L/s	0.0 L/s	235.0 L/s

**Task:** Create a schedule similar to that shown above. Note that the Room Pressurization property is a Calculated Value.

## Duct System Flows

The flows assigned to an air terminal are propagated through systems via ducts. Ducted supply and return tabulations are computed on the fly as the building model is iterated, and facilitates duct sizing, pressure drop inspection, and a variety of engineering checks such as duct velocity.

## Supply Air Distribution

Supply air is air that is mechanically tempered and delivered to a space. In general, the airflow is from an air handling unit, through a control/secondary tempering device such as a VAV box, and delivered to the space through the terminal. When ducts interconnect the components, the sum of the air terminal flows may be totaled back at the equipment supplying the air.

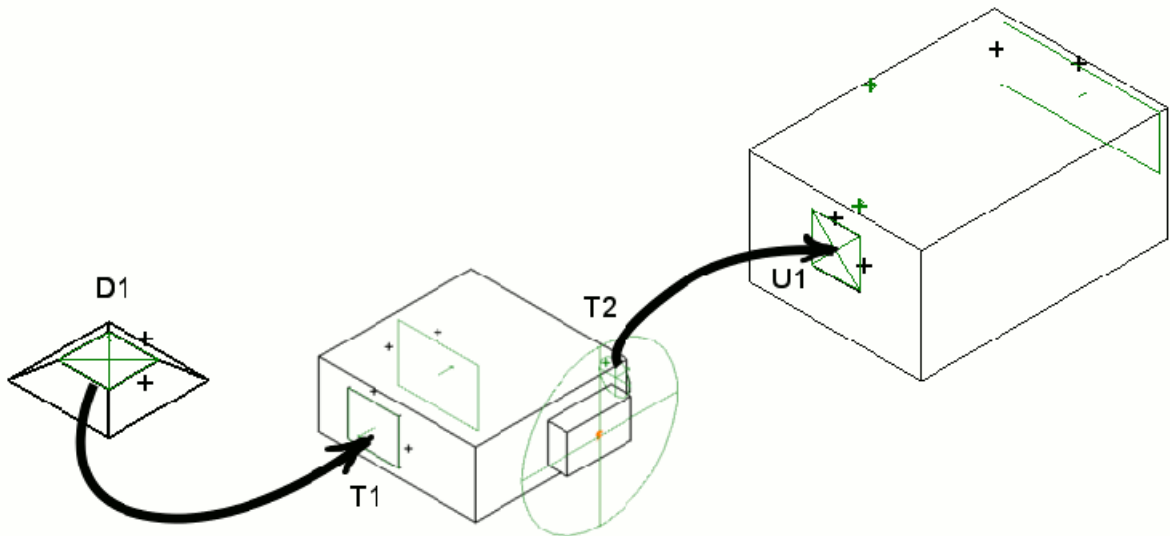

Note: The arrows indicate the 'flow' of the data, not the flow of the air. The designations (D1, T1, T2, U2) key the image to the table below, and are not found in Revit MEP.

## Duct Connector Settings

The duct connector settings have a significant impact on the ability for data to ‘flow’ through the duct system. Unexpected results may occur if the settings aren’t configured as needed for the desired outcome.

	Air Terminal	VAV Box		Air Handler
Parameter	D1	T1	T2	U1
Flow Configuration	Preset	Calculated	Preset	Calculated
Flow Parameter*	Flow	SupplyAirFlow	PrimaryAirFlow	AirFlow
Flow Direction	In	Out	In	Out
System Type	Supply Air	Supply Air	Supply Air	Supply Air
Loss Method	Specific Loss	Not Defined	Specific Loss	Not Defined
Pressure Drop Parameter *	Total Pressure	n/a	Pressure Drop	n/a

\* The actual name of the parameter is user defined in the Family. As such, the names in your content or in ‘out-of-the-box’ content may be different.

Air flow is assigned to the Air Terminal by the designer at D1. The total flow from the air terminals is calculated, and assigned to the SupplyAirFlow parameter at T1 on the VAV Box. PrimaryAirFlow is a function of SupplyAirFlow, and is assigned at T2. The total flow from all VAV boxes is calculated, and assigned to the AirFlow parameter at U1.

The net result is that the sum of the airflows from the air terminals is totalized into each VAV box, and the primary air requirements at each VAV box are totalized at each air handler.

---

**Task:** Create a simple ‘air valve’ Family, and a simple AHU Family with settings as shown above. Insert the components into a project, duct them together, and use a Duct Color Scheme Legend to show the Flow.

---



---

**Task:** Modify the AHU Family you created in the previous task to include a Calculated Return air connector.

---



---

**Task:** Create a ducted return system. Generally, there is no secondary component, such as a VAV box in the return system; just air terminals, the air handler, and duct. Verify that the return airflow specified on all the return grilles is computed back to the return connector on the air-handling unit.

---



---

**Task:** Create a simple exhaust fan, and create a ducted exhaust air system to an instance of the fan.

---



---

**Task:** Verify that you are on Subscription for your AutoCAD Revit MEP Suite software!

---

---

**Task:** From the Subscription site, download and read the Revit Platform 2009 Model Performance Technical Note, especially heed the item on page 35: "Create Systems"

---

## Creating Duct Systems

Systems can be created from equipment or air terminals:

1. Supply Air systems can be created containing families with a Supply Air IN Connector
2. Return Air systems can be created containing families with a Return Air OUT Connector
3. Exhaust Air systems can be created containing families with an Exhaust Air OUT Connector

---

Note: You cannot create an 'Other' air systems.

---

Mechanical Equipment Families can be the 'equipment for the system' using the following logic. The equipment must have a....

1. ...Supply Air OUT connector to be the equipment for a Supply Air system.
2. ...Return Air IN connector to be the equipment for a Return Air system.
3. ...Exhaust Air IN connector to be the equipment for an Exhaust Air system.

Thus, it is possible to create a system named 'Relief Air' by using components with Return or Exhaust system connectors. Similarly, a system named 'Outside Air' can be created using components with Supply system connectors.

## Pipe System Flows

### Chilled Water Loop

Chilled water is usually generated at a single central source, and distributed to multiple air-handlers as Supply Chilled Water (CHWS), and returns to the chiller as Return Chilled Water (CHWR). As air flows through the air handler, the chilled water cools and may also dehumidify the air.

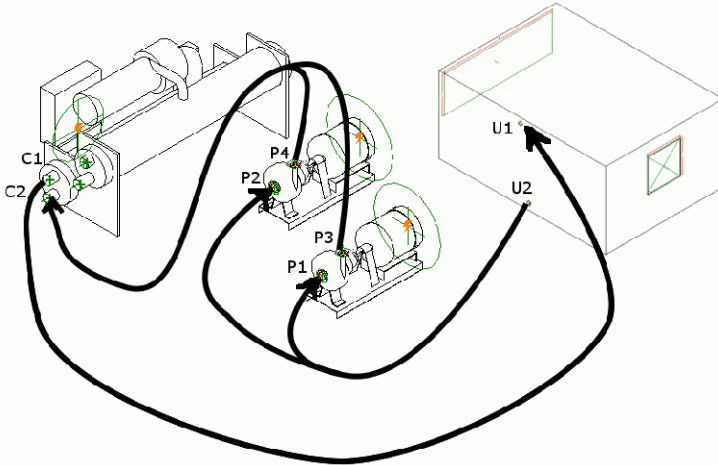

	Chiller		Air Handler		Pumps	
Parameter	C1	C2	U1	U2	P1/P2	P3/P4
Flow Configuration	Calculated	Calculated	Preset	Preset	System	System
Flow Parameter	Chilled Water Flow	Chilled Water Flow	CHWFlow	CHWFlow	Flow	Flow
Flow Factor Parameter	n/a	n/a	n/a	n/a	FlowFactor	FlowFactor
Flow Direction	Out	In	In	Out	In	Out
Loss Method	Specific Loss	Specific Loss	Specific Loss	Specific Loss	Not Defined	Not Defined
System Type	Hydronic Supply	Hydronic Return	Hydronic Supply	Hydronic Return	Global	Global
Pressure Drop Parameter	Chilled Water Pressure Drop	0.0	0.5 * PressureDrop	0.5 * PressureDrop	n/a	n/a
Connectors Linked? <sup>1</sup>	n/a		n/a		Yes	

1. Linked Connectors only have an effect when the System Type is set to Global, which is common for fittings and in-line components such as dampers, valves, and pumps. Essentially, Revit MEP will try to discern the system type, flow direction, and flow values if the connectors are linked.

---

**Task:** Add chilled water connectors to the AHU created earlier. Create a Chiller, and Pump family using the settings shown above. This is no time to be a hero, use simple 'boxy' geometry to learn about connectors... you can make the families pretty *after* you understand the concepts of flow!

---

## Condenser Water Loop

Condenser water (CW) is circulated through the chiller to absorb some of the heat from the building that is returned in the Return Chilled Water (CHWR). The CW is then circulated through the cooling tower to take advantage of 'free' evaporative cooling. As the water passes through the tower, some of the heat is rejected to the atmosphere.

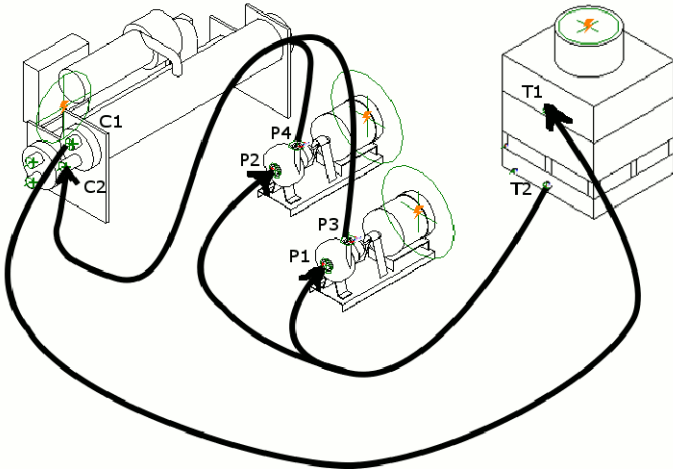

	Chiller		Cooling Tower		Pumps	
Parameter	C1	C2	T1	T2	P1/P2	P3/P4
Flow Configuration	Preset	Preset	Calculated	Calculated	System	System
Flow Parameter*	Cooling Water Flow	Cooling Water Flow	Cooling Water Flow	Cooling Water Flow	Flow	Flow
Flow Factor Parameter*	n/a	n/a	n/a	n/a	FlowFactor	FlowFactor
Flow Direction	Out	In	In	Out	In	Out
Loss Method	Specific Loss	Specific Loss	Specific Loss	Specific Loss	Not Defined	Not Defined
System Type	Hydronic Return	Hydronic Supply	Hydronic Return	Hydronic Supply	Global	Global
Pressure Drop Parameter*	Cooling Water Pressure Drop	0.0	0.0	Cooling Water Pressure Drop	n/a	n/a
Connectors Linked?	n/a		n/a		Yes	

## Pumps Piped in Parallel (System Flow Configuration)

The System Flow Configuration permits multiple pumps to share a portion of the total flow as shown below. For example, if total flow were 100 GPM, and the Flow Factor on the pumps were 0.6 and 0.4, the flow through each pump would be 60 GPM and 40 GPM respectively.

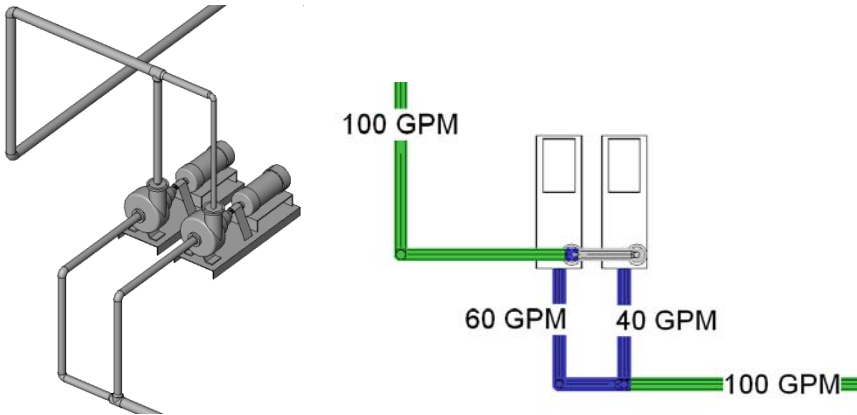

---

**Task:** Add condenser water connectors to the chiller created earlier. Create a cooling tower, use the pump Family created earlier.

---

---

**Task:** Create a hot water loop. Instead of a chiller, use boiler family (create/modify as necessary). Instead of connecting to chilled water connectors at a coil in the air handling unit, add connectors for hot water. The connectors will all still be Hydronic. Domestic Hot Water connectors are for domestic/tap hot water (and uses Fixture Units as the basis of flow), thus, not intended for use with building heating systems.

---

---

**Task:** Make sure you have created your Pipe Systems. Note that you can name them whatever you want, i.e., CHWR, HWR, CHWS, HWS, CWR, CWS, etc, are all perfectly valid system names. Create view filters and apply them to your view to verify that your systems are connected as expected.

---

## Fire Protection Systems

---

Note: Although there is a flow property on a Sprinkler, these flows are not computed on pipes or upstream equipment due to the nature of pipe sizing methodologies (NFPA-13) for such piping systems.

---

## Creating Pipe Systems

Systems can be created from Mechanical Equipment as follows:

1. Hydronic Supply systems can be created containing families with a Hydronic Supply IN connector.

2. Hydronic Return systems can be created containing families with a Hydronic Return OUT connector.

The following system types can be created from families containing IN or OUT connectors:

1. Domestic Cold Water
2. Domestic Hot Water
3. Fire Protection Dry
4. Fire Protection Other
5. Fire Protection Pre-Action
6. Fire Protection Wet
7. Other
8. Sanitary

The above system types use an instance of a Mechanical Equipment family as the equipment for the system.

## Power System Tabulations

Connectors on electrical equipment and components provide the pathway for electrical data to flow through the project, thereby providing a total connected load for the entire electrical distribution.

### Electrical Distribution

Electrical distribution is the infrastructure that supports electrical loads in the building. This generally refers to electrical equipment such as switchboards, panels, and transformers. In an electrical distribution there are commonly high-voltage components, such as switchboards, and high-voltage panels, and low-voltage panels. To interconnect the low-voltage panels to the high-voltage equipment, the load must pass through a transformer.

In this sample, 480/277v/3ph power enters the building through the conduit labelled 'FROM UTILITY TRANSFORMER'. The power to the building is therefore centralized at the switchboard SB1. Panel HA1 is a 480/277v/3ph/4wire panel, and as such, connects directly to SB1. Panel LA1 is a 208/120V/3ph/4w panel, and connects to SB1 through 480:208/120vtransformer T-LA1.

When connecting these components in Revit MEP, all connections are made 'upstream'. That is:

1. LA1 circuited to T-LA1
2. T-LA1 circuited to SB1
3. HA1 circuited to SB1

---

Note: There is no conduit functionality in Revit MEP at this time. The conduit shown in this document was created using Pipe, Pipe Fitting, and Flex Pipe components. The variable radius elbows were created by defining each radius as a separate type from a type catalog.

---

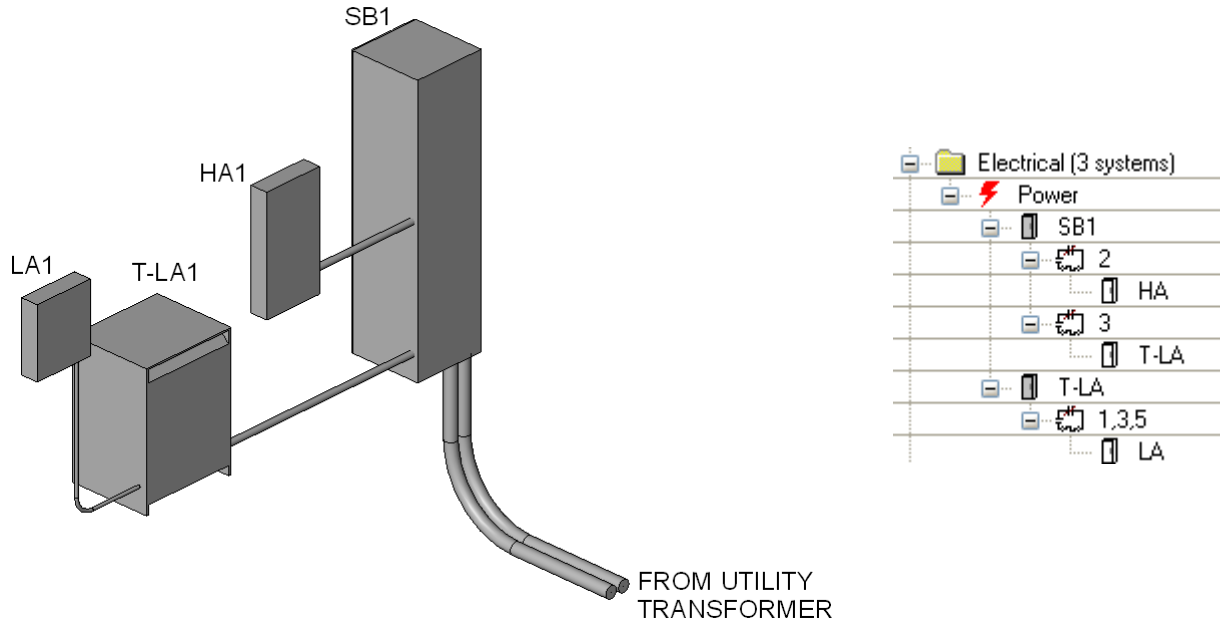

	Switchboard	High Voltage Panel	Transformer	Low Voltage Panel
Power Factor	0.8	1.0	1.0	1.0
Apparent Load Phase 3 (Power - Unbalanced only)	Apparent Load Phase C	Apparent Load Phase C	Apparent Load Phase C	Apparent Load Phase C
Apparent Load Phase 2 (Power - Unbalanced only)	Apparent Load Phase B	Apparent Load Phase B	Apparent Load Phase B	Apparent Load Phase B
Apparent Load Phase 1 (Power - Unbalanced only)	Apparent Load Phase A	Apparent Load Phase A	Apparent Load Phase A	Apparent Load Phase A
Apparent Load (Power - Balanced only)	n/a	n/a	n/a	n/a
Voltage	Switchboard Voltage (Type Parameter)	480.0	Primary Voltage	208.0
System Type	Power – Unbalanced	Power – Unbalanced	Power - Unbalanced	Power – Unbalanced
Load Classification	Power	Other	Other	Other
Power Factor State	Lagging	Lagging	Lagging	Lagging
Number of Poles	Number of Poles	3	Primary Number Of Poles	3

1. With a single-pole load, there is no difference in the result if Power – Unbalanced or Power-Balanced are used.

---

**Task:** Create a domestic electrical distribution system. This requires changing a panel board from 208/120v/3ph (3-pole) to 240/120v/1ph (2-pole). Refer to AMEP 2009 Family Editor Tutorials.

---

---

**Task:** Create a commercial electrical distribution system. You will first need to create the Voltage Definitions and Distribution Systems in Settings > Electrical Settings... as appropriate for your country.

---

---

**Note:** Without knowing the voltage definitions and distribution systems that are utilized in your country, it will not be possible to create lighting or power connections that are appropriate.

---

## Electrical Loads

Electrical loads are typically the power consuming components in a building: Lighting fixtures, power devices, mechanical equipment, etc. It is not common to show the conduit between each device, or even between the device and the panel. Rather, a schematic representation is typically sufficient to convey the requirements.

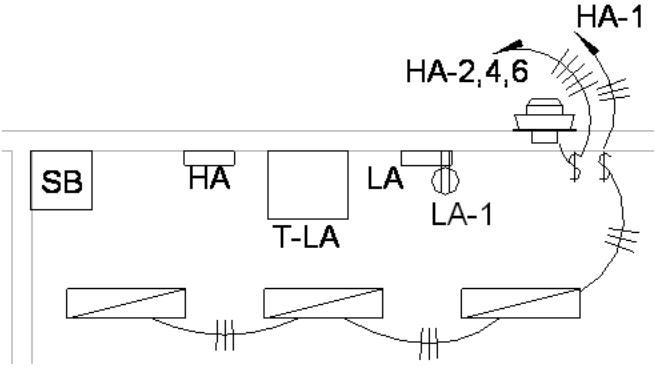
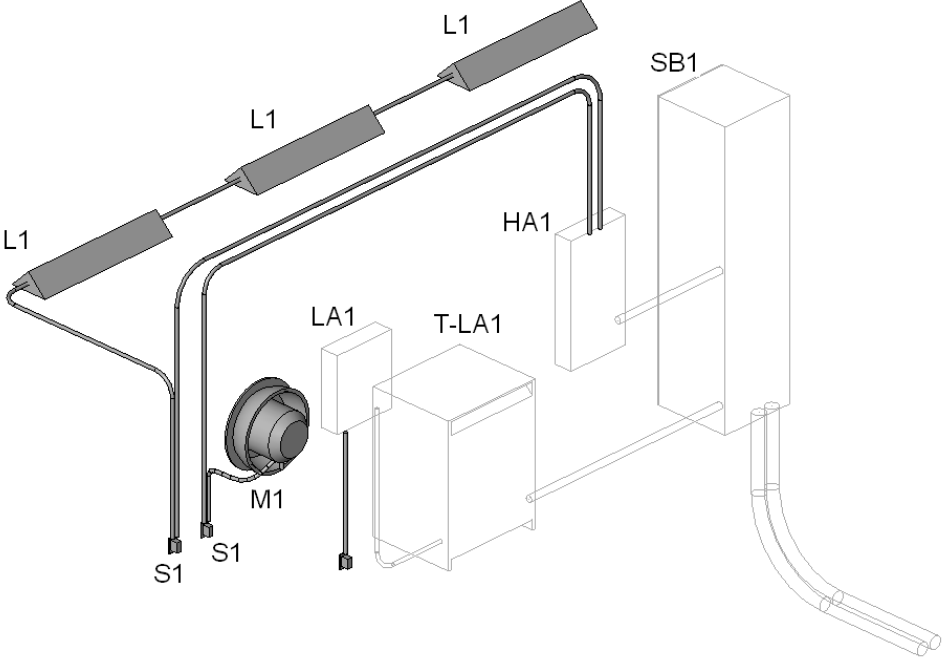



	Light Fixture	Receptacle	Appliance	Mechanical Motor / Fan	Switch
Power Factor	0.95	1.0	0.9	0.8	1.0
Apparent Load Phase 3 (Power - Unbalanced only)	n/a	n/a	n/a	n/a	n/a
Apparent Load Phase 2 (Power - Unbalanced only)	n/a	n/a	n/a	n/a	n/a
Apparent Load Phase 1 (Power - Unbalanced only)	Apparent Load	Load	n/a	n/a	0.0
Apparent Load (Power - Balanced only)	n/a	n/a	Load	Apparent Load	n/a
Voltage	Ballast Voltage	Switch Voltage	Switch Voltage	Voltage	Switch Voltage <sup>2</sup>
System Type	Power – Unbalanced <sup>1</sup>	Power – Unbalanced <sup>1</sup>	Power – Balanced	Power – Balanced	Power – Unbalanced
Load Classification	Lighting	Power	Other	HVAC	Lighting
Power Factor State	Lagging	Lagging	Lagging	Lagging	Lagging
Number of Poles	1 <sup>1</sup>	1 <sup>1</sup>	2	Number of Poles	1

1. With a single-pole load, there is no difference in the result if Power – Unbalanced or Power-Balanced are used.
2. The switch voltage is an instance family parameter.

## Power Factor

The power factor applied to a connector allows one to track true power vs. apparent power. Motors and other inductive loads tend to have lagging power factors, whereas capacitors have leading power factors. Purely electric loads, such as incandescent lights and electric heat, tend to have unity (1.0) power factors.

With a Power Factor of 1.0, the Power Factor State (Leading/Lagging) has no affect.

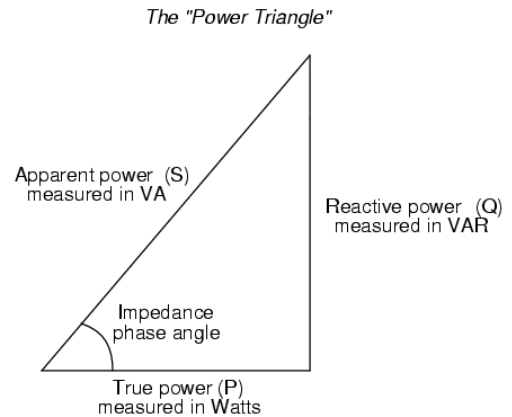

## Voltage

Voltage is the difference in electrical potential between two points. Voltage in a circuit is the ‘force’ that causes energy to ‘flow’. This can be thought of as the ‘pressure’ in the circuit. In fact, in electrical design, there are voltage losses in the system, known as ‘Voltage Drop’. However, these drops are insignificant at individual connectors/components, and are commonly only computed in the feeders between equipment and devices.

## Load Classification

Depending on the type of load, different demand factor computations may be applicable when calculating equipment and feeder sizes.

A space schedule tabulating electrical loads can be a handy engineering tool for verifying power consumption, particularly with Lighting and the International Energy Conservation Code requirements.

Room Power Distribution Schedule							
Name	Number	Actual HVAC Load	Actual Lighting Load	Actual Lighting Load per area	Actual Power Load	Actual Power Load per area	Actual Other Load
Room	1	0 W	365 W	6.36 W/m <sup>2</sup>	0 W	0.00 W/m <sup>2</sup>	0 W
Room	2	0 W	730 W	5.02 W/m <sup>2</sup>	180 W	1.24 W/m <sup>2</sup>	0 W
Room	3	0 W	547 W	7.77 W/m <sup>2</sup>	0 W	0.00 W/m <sup>2</sup>	0 W
Room	4	0 W	182 W	6.57 W/m <sup>2</sup>	0 W	0.00 W/m <sup>2</sup>	0 W
Room	5	56000 W	365 W	4.19 W/m <sup>2</sup>	0 W	0.00 W/m <sup>2</sup>	0 W
Room	6	0 W	1094 W	4.95 W/m <sup>2</sup>	0 W	0.00 W/m <sup>2</sup>	271 W

## Load

The load is the amount of power drawn by a circuit. This can be thought of as the ‘flow’ in the circuit.

## Number of Poles

The number of poles indicates how the component is circuited. Acceptable values are 1, 2, or 3.

The figure below depicts the relationship between the number of poles, and how wires are connected to equipment bus bars to create a circuit. The vertical lines labelled A, B, C, Neutral, and Ground represent the bus bars in a panel. The vertical dashed line represents the equipment enclosure. The vertical lines represent the wires connected to the bus bars. Each of the three groups of wires represents a separate circuit.

---

Note: A simplification of this diagram is what electrical engineers/designers refer to as the one-line diagram. In a one-line, instead of diagramming each wire in a circuit, a circuit is represented as a single line, and annotated to indicate its contents.

---

Diagram	Description
<p>The diagram illustrates three circuit configurations on a 4-wire system. The system phases are labeled A, B, C, Neutral, and Ground. The top circuit is a three-pole circuit tapping all three phases (A, B, C) and the Neutral. The middle circuit is a two-pole circuit tapping phases A and B, plus the Neutral and Ground. The bottom circuit is a one-pole circuit tapping phase A, plus the Neutral and Ground.</p>	<p><b>Three Pole Circuit:</b> A three-pole circuit taps off all three phases. This is also known as a 3-phase/3-wire circuit. A 4-wire circuit has an additional wire for the Neutral; this is used if the circuited component has single-pole loads. In almost all installations, a ground wire is also required.</p> <p><b>Two Pole Circuit:</b> A two-pole circuit may tap off of any pair of phases, A-B, B-C, or A-C. The two-pole circuit here is tapping off of phases A-B. In some cases, there may also be a Neutral conductor if the circuited component has single-pole loads. In almost all installations, a ground wire is also required.</p> <p><b>One Pole Circuit:</b> A single-pole circuit may tap off of any of the phases, A, B, or C. The circuit shown here is tapping off the A phase. There will always be a Neutral conductor in a one-pole circuit. In almost all installations, a ground wire is also required.</p>

---

**Task:** Make sure each piece of mechanical equipment requiring power in your model has a power connector, and is circuited.

---

## Lighting Content

Lighting fixtures are made of variety of different materials, and come in a variety of different shapes and sizes. Additionally, there are a variety of different types of lamps and ballasts. All these variables

contribute to how light is distributed from the fixture. Lighting manufacturers subject their fixtures for photometric testing, and generally provide an .ies file that represents the result of this test. Revit utilizes these .ies files to compute the Average Estimated Illumination in a space.

Lighting fixtures contribute to Average Estimated Illumination (AEI) in Spaces. This calculation is dependent on several parameters:

1. IES file name (no .ies extension)
2. Existence of electrical connector.
3. Light Loss Factor
4. Ballast Factor
5. Coefficient of Utilization
6. Lumens

---

**Task:** Find a light fixture cut-sheet and associated .ies file on the Internet. Create the family using the concepts in the “Creating a Light Fixture Family” section in the Metric Family Editor Tutorial. You may want to start at a manufacturer’s website to find an .ies file of interest.

---

## References

### Autodesk University

- 2007 Course: ME318-1L Creating Revit® MEP Content for Engineering Coordination
- 2006 Course: ME23-1 Creating Autodesk® Revit® Systems Content for Engineering Coordination

### Product Tutorials

- <http://www.autodesk.com/revitmep-documentation>

### Internet Postings

- <http://inside-the-system.typepad.com/>
- <http://discussions.autodesk.com>

## Reference Matrix

This matrix shows what concepts may be found in what reference.

	Geometry	Shared Parameters	Family Parameters	Lookup Tables	Types	Type Catalog	Connectors			Parameter Mapping	Multi-Discipline Family	Annotation	API
							Duct	Pipe	Electrical				
<b>AU 2006: ME23-1</b>													
Electric Water Heater		✓	✓		✓				✓	✓	✓		
Valve	✓		✓	✓				✓		✓			
<b>AU2007: ME318-1L</b>													
Exhaust Fan	✓	✓	✓			✓			✓	✓	✓		
<b>RMEP 2009 Family Editor Tutorials</b>													
Modify a Fan Family		✓	✓		✓					✓			
Modify Fan VAV w/ Elec Heat		✓	✓		✓		✓		✓	✓	✓		
Modify Electrical Equipment			✓		✓				✓	✓			
Modify a Water Closet								✓					
Modify Diffuser Annotation												✓	
Modify Light Fixture Annotation												✓	
Create Light Fixture	✓				✓				✓	✓			
Create Flange	✓		✓	✓				✓		✓			
Create Elbow Pipe Fitting	✓		✓	✓				✓		✓			
Create Annotation Symbol												✓	
<b>ADN Revit MEP - API Samples</b>													
Assign Flow to Terminals				✓									✓
Change Size of Terminal				✓	✓								✓
Calculate room CFM/SF				✓									✓
Find unhosted elements				✓									✓